

Oil & Filter Recycler Specifications

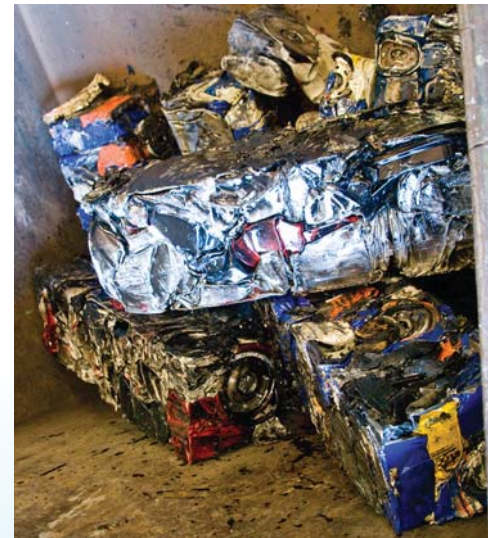
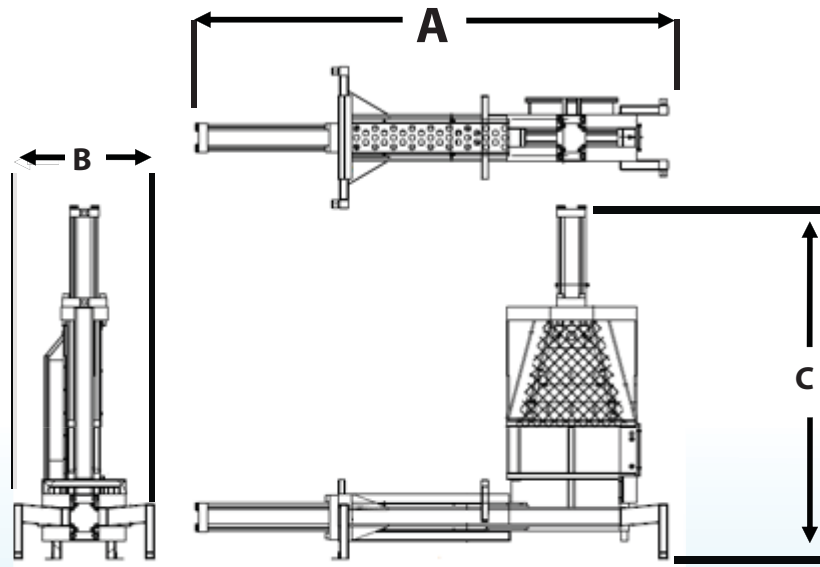

PROCESSED FILTER BRICKS

Oil & Filter Recycler

O.A. Length "A"	205"
O.A. Width "B"	62"
O.A. Height "C"	153"
Chamber Length	40"
Base Weight	5 TONS
Sump Capacity	250 GAL
Cycle Time (Sec.)	75*

Electrical

Motor	30HP
Power	230/460V 3PH
Amps	80 / 40
PLC Type	AB MicroLogix 1400
Controls	AB Push Buttons
Main Enclosure	NEMA 12
Approvals	UL Listed Main Panel

* Cycle Time varies with filter size

Brick Dimensions

6"W X 6"H X VARIABLE

Hydraulic

Main Pump	47 GPM Piston
Hyd. Pressure	2500 Max.
Ram Cylinder	(1) 10" X 48"
Force Feed Cyl.	(1) 10" X 30"
Gate Cylinder	(1) 4" X 8"
Ram Force	196,000 LBs (Max)
Force Feeder	196,000 LBs (Max)
Cycle Time	75 Seconds Typical

Dumper Motor	3 HP
Dumper Pump	4.5 GPM Vane
Dumper Cylinder	(1) 4" X 30"
Dumper Cycle	38 Seconds

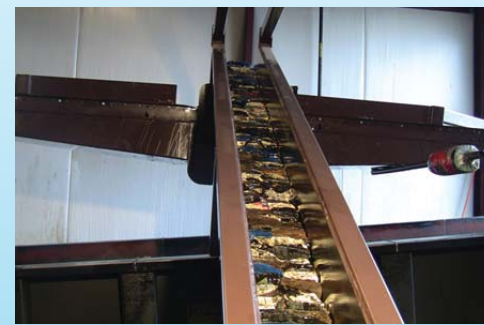

Due to product improvement, the manufacturer reserves the right to alter or amend, without notice, any of these specifications and/or dimensions



Oil & Filter Recycler

**Dump, Sort, Crush and Reclaim Oil
In One Clean Operation**

- Heavy Duty Construction
- Superior Oil Recovery
- Containment Features for a Cleaner Workplace
- Process Up to 13 Barrels of Filters per Hour



Bright Technologies, a Specialty Division of Sebright Products, Inc.
127 N. Water St., Hopkins, MI 49328
Phone: 269-793-7183 Fax: 269-793-8793
Toll Free US: 800-253-0532

www.brightbeltpress.com ~~~www.sebrightproducts.com

copyright 2012

800-253-0532

www.sebrightproducts.com

www.brightbeltpress.com

Oil & Filter Recycler System

Simple & Efficient for Oil & Steel Recovery

PROCESS FILTERS FROM IMPORTS TO SEMI SIZES

- PROCESS UP TO 13 BARRELS PER HOUR
- SUPERIOR OIL RECOVERY
- METERING SCOOP REDUCES SHEERING & JAMS

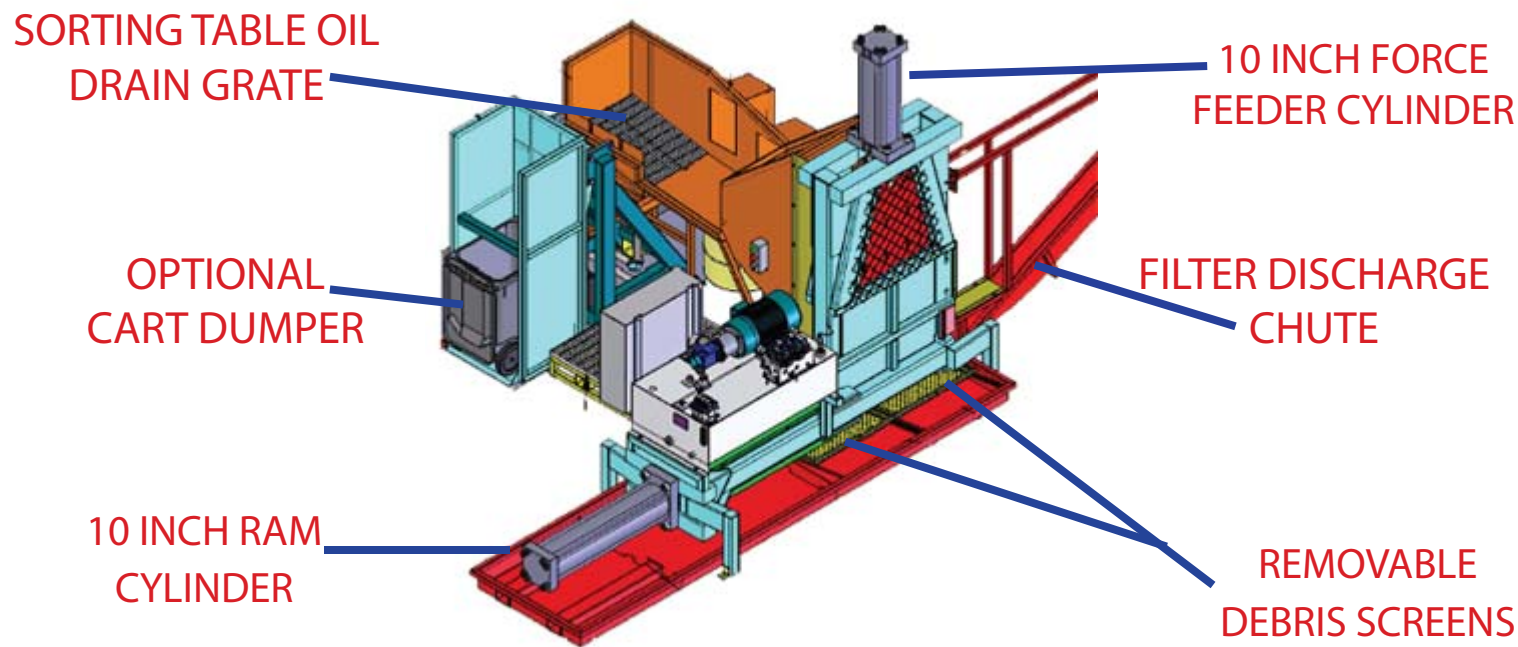

The Bright Technologies Oil & Filter Recycler is the answer for processing large volumes of oil filters. The powerful 10 inch cylinder design develops up to 196,000 lbs of force. A full range of options are offered to make a custom system that fits your needs.

The optional cart dumper accepts 55 gallon barrels or 90 gallon plastic carts of filters and has an oil pocket to reduce oil seepage and clean up!

The Optional Sorting Table has an integral screen and drain to allow dumping of partially oil filled barrels. The two disposal openings allow quick and convenient removal of foreign materials. Filters to be processed are merely pushed to the hopper opening. The feed hopper holds approximately 3 cycles of filters allowing the operator to change barrels while the machine is processing.

The proprietary metering scoop collects a fixed volume of filters and feeds them into the machine each cycle to reduce sheering and jamming issues. The discharge chute aids additional free drainage of the compressed filter "bricks".

System Options

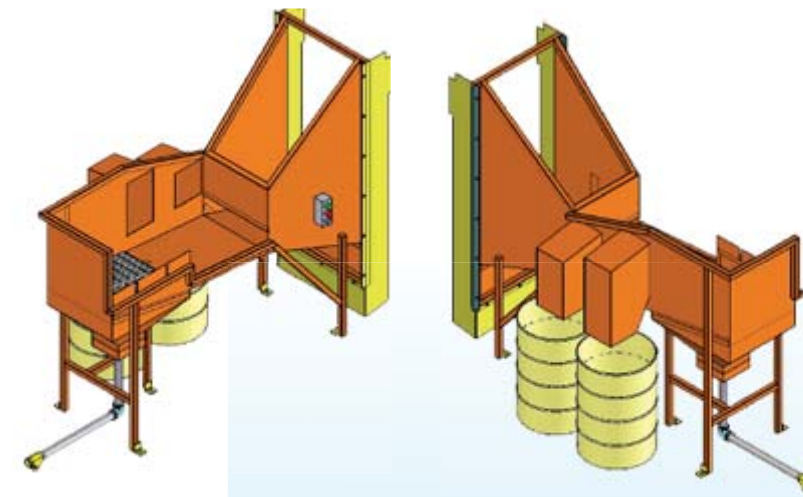

SORTING TABLE

- OIL COLLECTION GRATE & DRAIN
- 2 REFUSE DISPOSAL OPENINGS
- INCLINED HOPPER AREA

CART DUMPER

- SAFE & ERGONOMIC
- ACCEPTS BARRELS OR CURB CARTS
- DESIGN REDUCES OIL DRIPS TO FLOOR

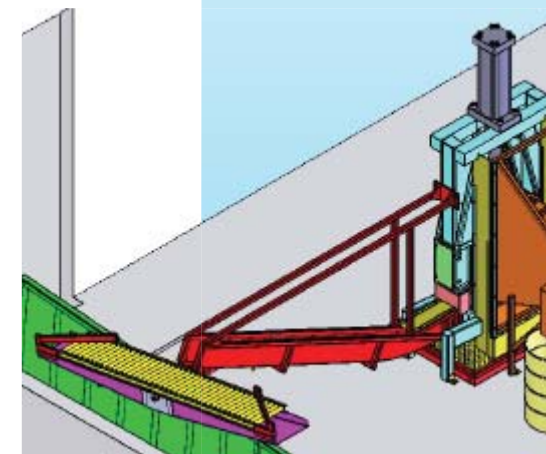

ROLL OFF CONTAINER

DISTRIBUTION CONVEYOR

- DROPS FILTER BRICKS IN 3 POSITIONS
- OPERATOR ADJUSTED DROP POSITION
- USES GRAVITY, NO POWER REQUIRED
- SUPPORTED BY THE CHUTE & MACHINE



OTHER OPTIONS

- LEFT OR RIGHT HAND FEED
- CUSTOM FEED HOPPERS
- ROLL OFF CONTAINERS
- OIL HOLDING TANKS