

NOTE:

1. COMPACTOR MODEL: 5260HD-1-7 WITH REINFORCE BREAKER BAR AND ADD LONG HINGED RETAINER TEETH
2. COLOR:
3. VOLTAGE:
4. 15 HP POWER UNIT, SPECIAL MULTI-CYCLE, WITH COVER
5. PANEL WIRED OIL HEATER WITH PREMIUM ALL WEATHER HYDRAULIC OIL
6. REMOTE PRESSURE GAUGE
7. #11 GAUGE ENCLOSURE, SAFETY GATE WITH INTERLOCK, AND 800# DECK / WALK ON ONLY, NO FORKLIFTS
8. PRESSURE BOOST OVERRIDE SYSTEM
9. POWER EXHAUST FAN: MODEL 4YC69 INSTALLED BY SEBRIGHT, ELECTRICAL CONDUIT BY OTHERS / 115 VOLT / SINGLE PHASE / 1/3 HP FAN
10. CONTAINER BY OTHERS
11. CONTAINER GUIDE RAILS 4" TALL X 60" LONG
12. SET FULL LIGHT AT 1600 PSI, BOOST AT 1900 PSI
13. EXTRA (2) COMPACTOR LEGS AND ANCHORING ANGLES FOR HOLDING STRENGTH
14. STEEL WEAR PLATES BY OTHERS

PRINTED DATE AND TIME: 2020/04/03 11:02:21 AM DATE: 2020/04/03 REVISION: DRAWN BY: BD SHEET 1 OF 7

DRAWING LEGEND - CONFIDENTIAL
 This drawing is the sole property of Sebright Products Inc., and embodies confidential proprietary information. All rights in this document and in the information contained herein are reserved by Sebright Products Inc. The document is provided for a specific purpose, and the document and the contents thereof may not be reproduced, used or disclosed to others for any other purpose without the express written consent of Sebright Products Inc. and the drawing must be returned to Sebright Products Inc. when the specific purpose is completed.

TOLERANCE (UNLESS SPECIFIED)
 FRACTIONS ± 1/16"
 .XXXX ± 0.025"
 ANGLES ± 0°30'

TITLE: GENERIC SALES LAYOUT			
SEBRIGHT PRODUCTS INC. 127 N. WATER ST. HOPKINS, MI 49328 PH 269-793-7183 / www.sebrightproducts.com			CUSTOMER NAME: WEIGHT (LBS): SCALE: 1:54 SHEET SIZE: A DWG #: 10669-GENERIC
MATERIAL: SER. NO.:			

EXHAUST FAN
(WIRED BY OTHERS)

ELECTRICAL
DISCONNECT
BY OTHERS

SHOW WITH
LEFT HAND
SIDE MOUNTED
POWER UNIT

CONTAINER GUIDE RAILS

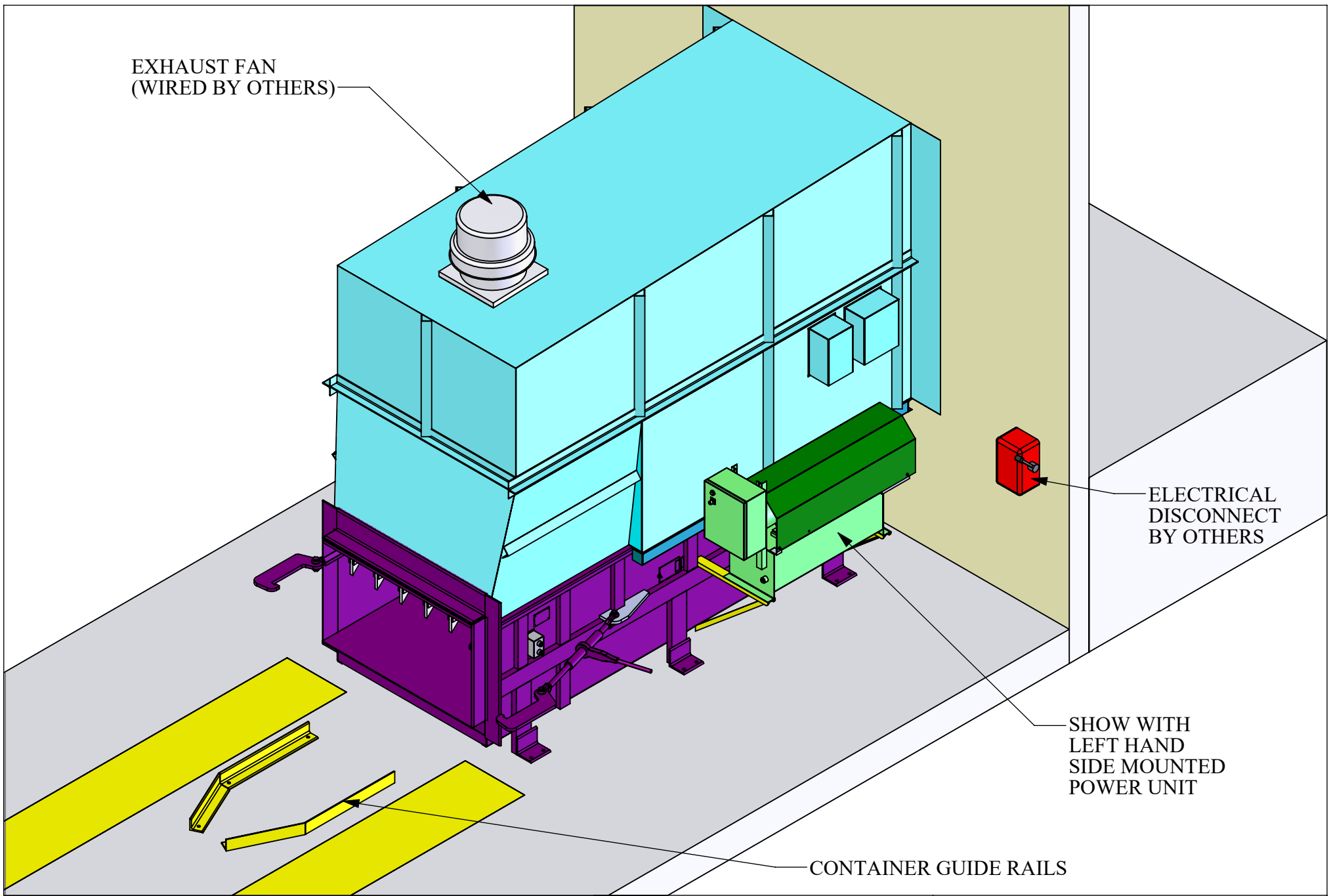

PRINTED DATE AND TIME: 2020/04/03 11:02:21 AM DATE: 2020/04/03 REVISION: DRAWN BY: BD SHEET 2 OF 7

TITLE: **GENERIC SALES LAYOUT**

DRAWING LEGEND - CONFIDENTIAL
This drawing is the sole property of Sebright Products Inc., and embodies confidential proprietary information. All rights in this document and in the information contained herein are reserved by Sebright Products Inc. The document is provided for a specific purpose, and the document and the contents thereof may not be reproduced, used or disclosed to others for any other purpose without the express written consent of Sebright Products Inc. and the drawing must be returned to Sebright Products Inc. when the specific purpose is completed.

TOLERANCE
(UNLESS SPECIFIED)
FRACTIONS ± 1/16"
.XXXX ± 0.025"
ANGLES ± 0°30'

SEBRIGHT PRODUCTS INC.
127 N. WATER ST. HOPKINS, MI 49328
PH 269-793-7183 / www.sebrightproducts.com

CUSTOMER NAME:			
WEIGHT (LBS):	SCALE: 1:36	SHEET SIZE: A	DWG #:
MATERIAL:	SER. NO.:	10669-GENERIC	



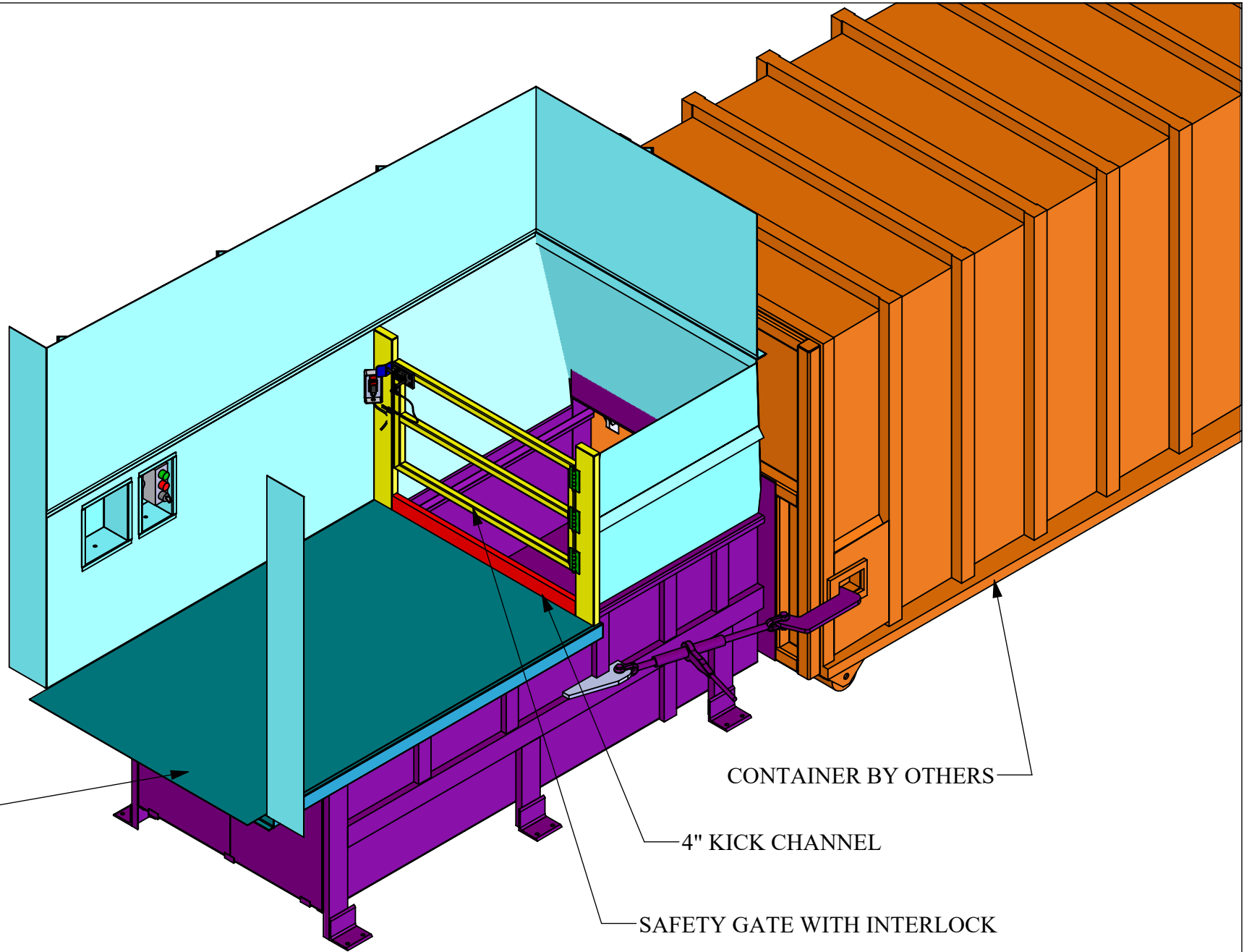
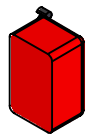

800# DECK

CONTAINER BY OTHERS

4" KICK CHANNEL

SAFETY GATE WITH INTERLOCK

PRINTED DATE AND TIME: 2020/04/03 11:02:21 AM DATE: 2020/04/03 REVISION: DRAWN BY: BD SHEET 3 OF 7

TITLE:

GENERIC SALES LAYOUT

DRAWING LEGEND - CONFIDENTIAL
 This drawing is the sole property of Sebright Products Inc., and embodies confidential proprietary information. All rights in this document and in the information contained herein are reserved by Sebright Products Inc. The document is provided for a specific purpose, and the document and the contents thereof may not be reproduced, used or disclosed to others for any other purpose without the express written consent of Sebright Products Inc. and the drawing must be returned to Sebright Products Inc. when the specific purpose is completed.

TOLERANCE
 (UNLESS SPECIFIED)
 FRACTIONS ± 1/16"
 .XXXV ± .0625"
 ANGLES ± 0°30'

SEBRIGHT PRODUCTS INC.
 127 N. WATER ST. HOPKINS, MI 49328
 PH 269-793-7183 / www.sebrightproducts.com



CUSTOMER NAME:			
WEIGHT (LBS):	SCALE: 1:32	SHEET SIZE: A	DWG #:
MATERIAL:	SER. NO.:	10669-GENERIC	

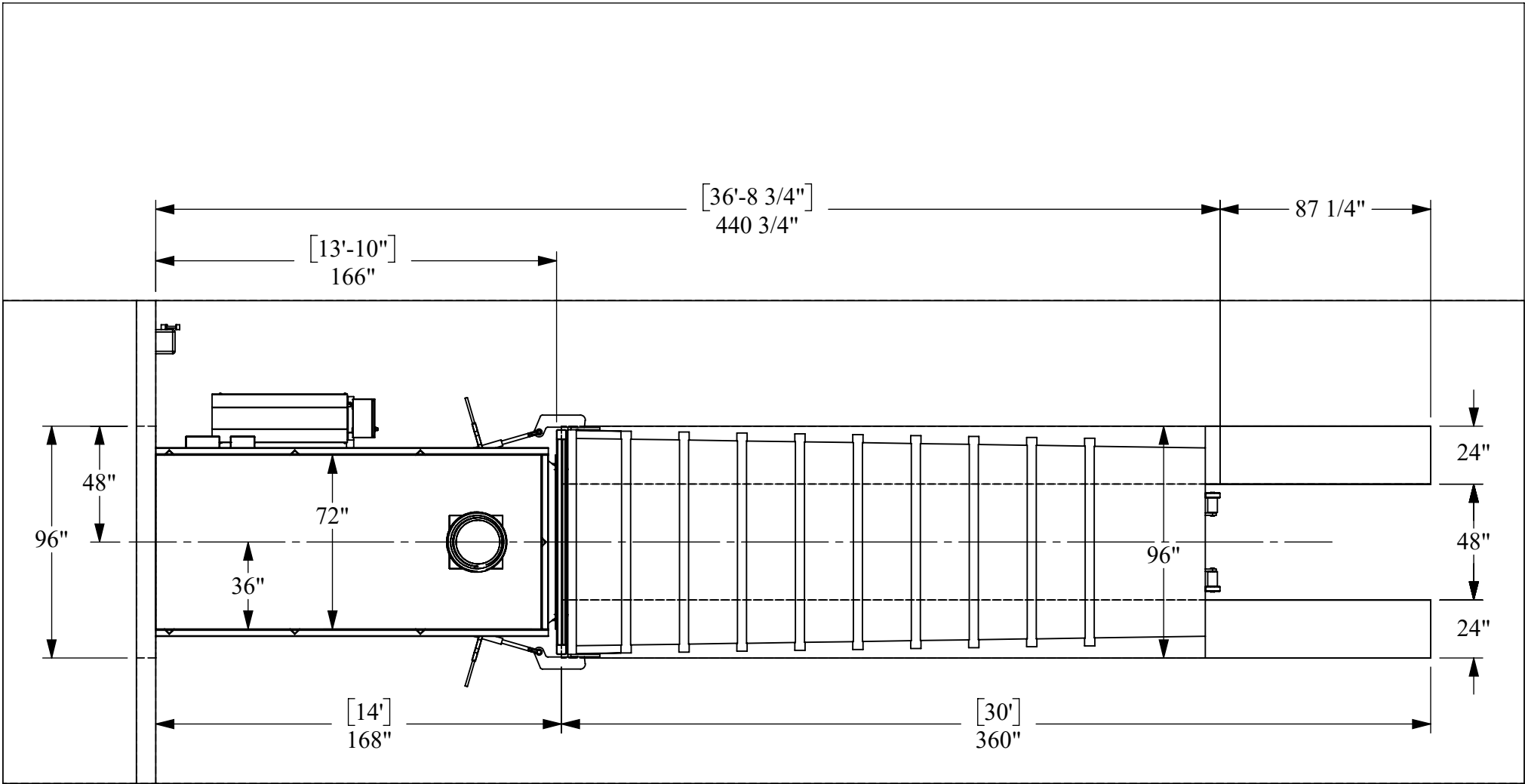

PRINTED DATE AND TIME: 2020/04/03 11:02:21 AM DATE: 2020/04/03 REVISION: DRAWN BY: BD SHEET 4 OF 7

TITLE: **GENERIC SALES LAYOUT**

DRAWING LEGEND - CONFIDENTIAL
 This drawing is the sole property of Sebright Products Inc., and embodies confidential proprietary information. All rights in this document and in the information contained herein are reserved by Sebright Products Inc. The document is provided for a specific purpose, and the document and the contents thereof may not be reproduced, used or disclosed to others for any other purpose without the express written consent of Sebright Products Inc. and the drawing must be returned to Sebright Products Inc. when the specific purpose is completed.

TOLERANCE (UNLESS SPECIFIED)
 FRACTIONS $\pm 1/16"$
 .XXXX $\pm 0.025"$
 ANGLES $\pm 0'30"$

SEBRIGHT PRODUCTS INC.
 127 N. WATER ST. HOPKINS, MI 49328
 PH 269-793-7183 / www.sebrightproducts.com

CUSTOMER NAME:
 WEIGHT (LBS): SCALE: 1:60 SHEET SIZE: A DWG #: 10669-GENERIC
 MATERIAL: SER. NO.:



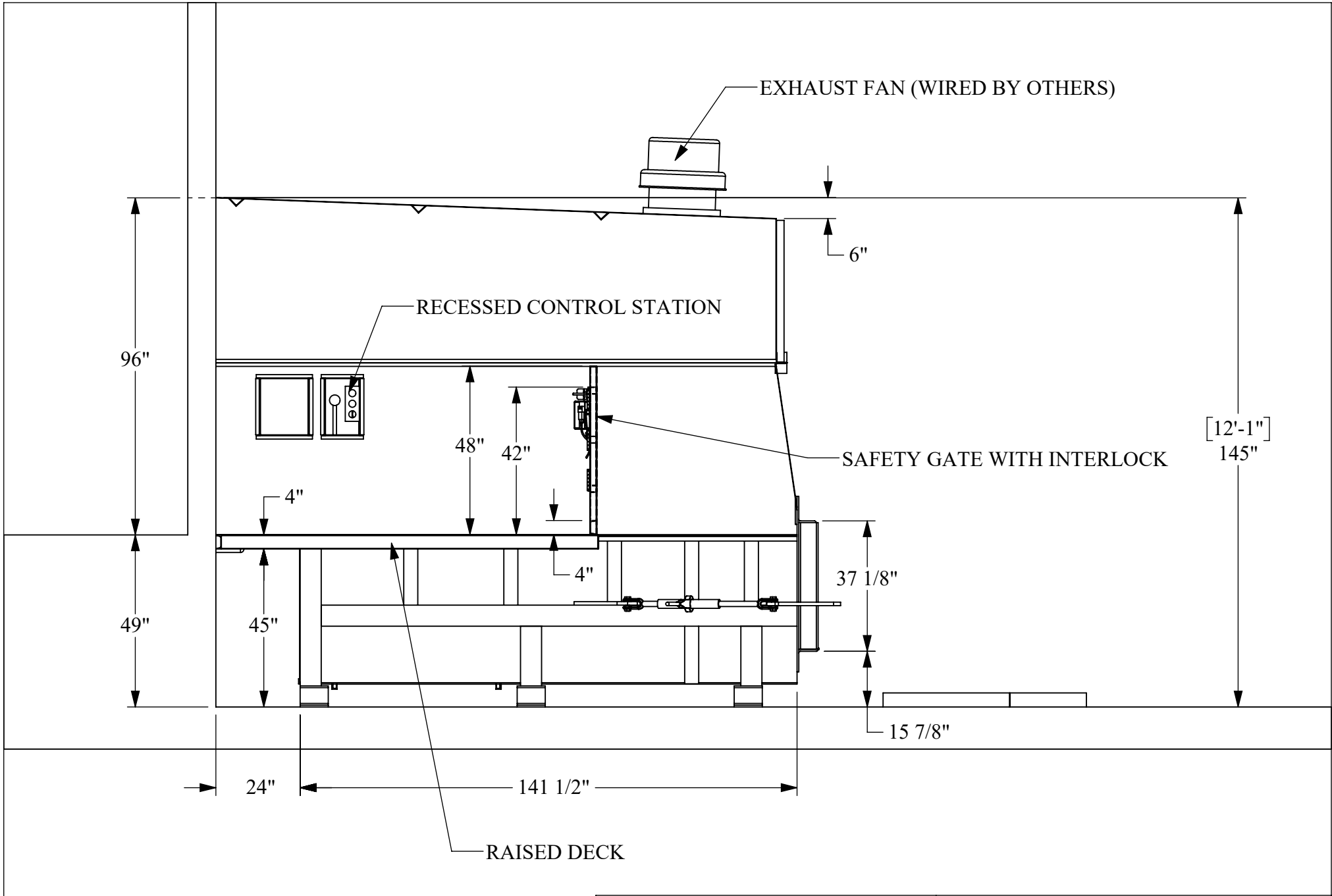

PRINTED DATE AND TIME: 2020/04/03 11:02:21 AM		DATE: 2020/04/03	REVISION:	DRAWN BY: BD	SHEET 5 OF 7	TITLE: GENERIC SALES LAYOUT	
DRAWING LEGEND - CONFIDENTIAL This drawing is the sole property of Sebright Products Inc., and embodies confidential proprietary information. All rights in this document and in the information contained herein are reserved by Sebright Products Inc. The document is provided for a specific purpose, and the document and the contents thereof may not be reproduced, used or disclosed to others for any other purpose without the express written consent of Sebright Products Inc. and the drawing must be returned to Sebright Products Inc. when the specific purpose is completed.						TOLERANCE (UNLESS SPECIFIED) FRACTIONS ± 1/16" .XXXX ± 0.025" ANGLES ± 0°30"	
SEBRIGHT PRODUCTS INC. 127 N. WATER ST. HOPKINS, MI 49328 PH 269-793-7183 / www.sebrightproducts.com						CUSTOMER NAME: WEIGHT (LBS): SCALE: 1:36 SHEET SIZE: A DWG #: 10669-GENERIC	
MATERIAL:						SER. NO.:	

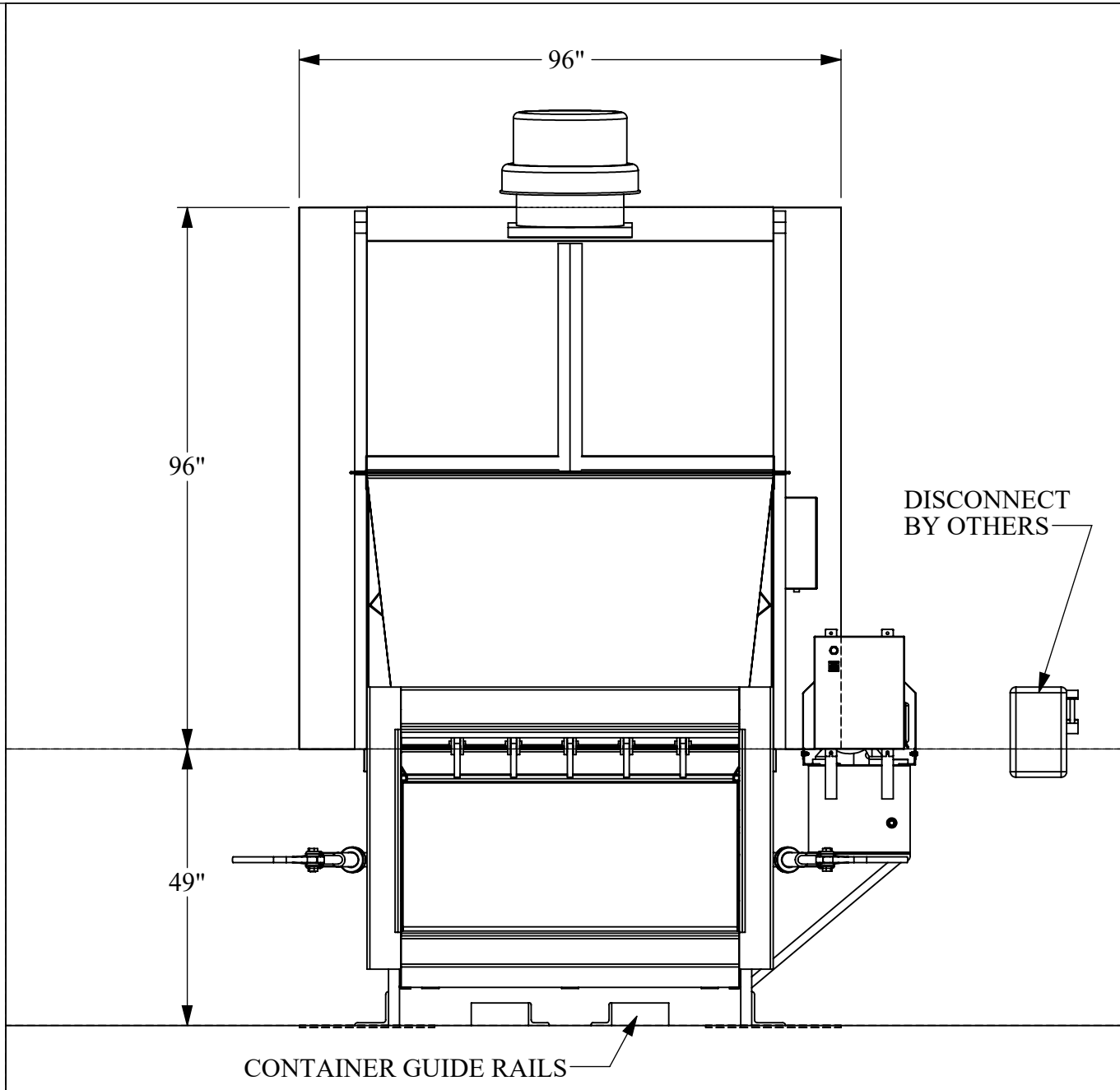

PRINTED DATE AND TIME: 2020/04/03 11:02:21 AM DATE: 2020/04/03 REVISION: DRAWN BY: BD SHEET 6 OF 7

TITLE: **GENERIC SALES LAYOUT**

DRAWING LEGEND - CONFIDENTIAL
 This drawing is the sole property of Sebright Products Inc., and embodies confidential proprietary information. All rights in this document and in the information contained herein are reserved by Sebright Products Inc. The document is provided for a specific purpose, and the document and the contents thereof may not be reproduced, used or disclosed to others for any other purpose without the express written consent of Sebright Products Inc. and the drawing must be returned to Sebright Products Inc. when the specific purpose is completed.

TOLERANCE
 (UNLESS SPECIFIED)
 FRACTIONS ± 1/16"
 .XXXV ± 0.025"
 ANGLES ± 0°30'

SEBRIGHT PRODUCTS INC.
 127 N. WATER ST. HOPKINS, MI 49328
 PH 269-793-7183 / www.sebrightproducts.com



CUSTOMER NAME:			
WEIGHT (LBS):	SCALE: 1:28	SHEET SIZE: A	DWG #:
MATERIAL:	SER. NO.:	10669-GENERIC	

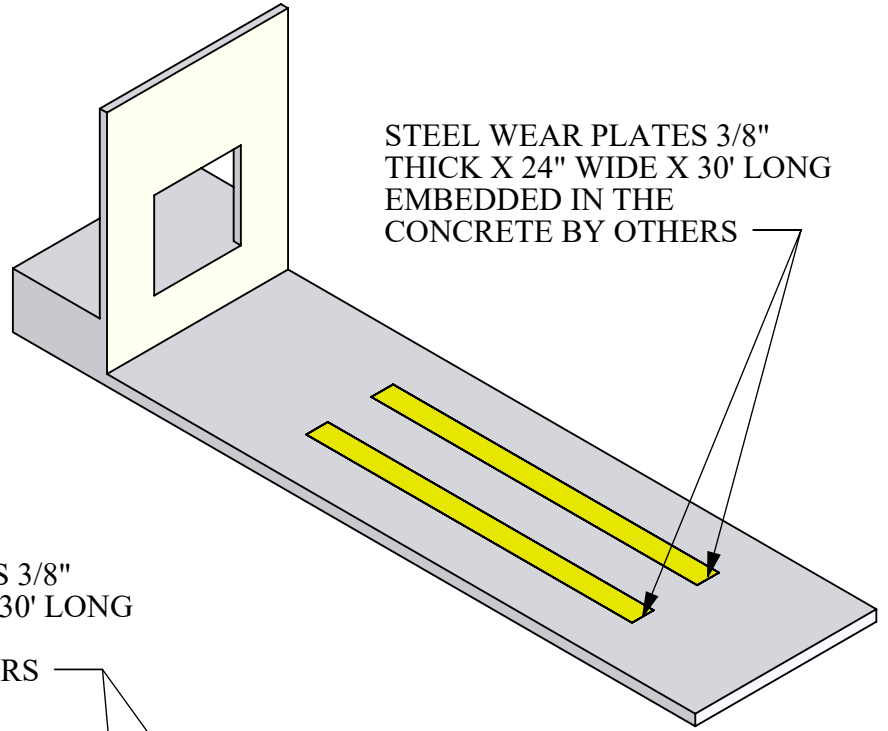

STEEL WEAR PLATES 3/8"
THICK X 24" WIDE X 30' LONG
EMBEDDED IN THE
CONCRETE BY OTHERS

STEEL WEAR PLATES 3/8"
THICK X 24" WIDE X 30' LONG
EMBEDDED IN THE
CONCRETE BY OTHERS

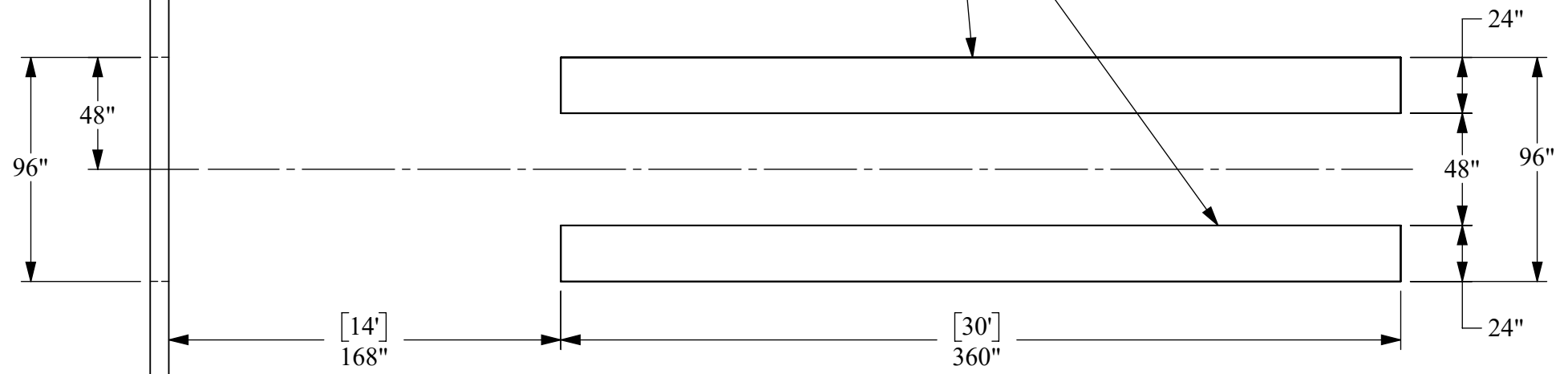

PRINTED DATE AND TIME: 2020/04/03 11:02:21 AM DATE: 2020/04/03 REVISION: DRAWN BY: BD SHEET 7 OF 7				TITLE: SITE LAYOUT			
DRAWING LEGEND - CONFIDENTIAL This drawing is the sole property of Sebright Products Inc., and embodies confidential proprietary information. All rights in this document and in the information contained herein are reserved by Sebright Products Inc. The document is provided for a specific purpose, and the document and the contents thereof may not be reproduced, used or disclosed to others for any other purpose without the express written consent of Sebright Products Inc. and the drawing must be returned to Sebright Products Inc. when the specific purpose is completed.				TOLERANCE (UNLESS SPECIFIED) FRACTIONS ± 1/16" .XXXV ± 0.025" ANGLES ± 0°30'		SEBRIGHT PRODUCTS INC. 127 N. WATER ST. HOPKINS, MI 49328 PH 269-793-7183 / www.sebrightproducts.com	
CUSTOMER NAME:		WEIGHT (LBS):		SCALE: 1:66		SHEET SIZE: A	
MATERIAL:		SER. NO.:		DWG #: 10669-GENERIC			